



RIEGER

NEUMO Ehrenberg Group

BioFlow

cGMP Check Valves

for pharmaceutical and sterile applications



cGMP Check Valves for pharmaceutical and sterile applications

Protect your valuable pumps and instruments from damage by using self-acting cGMP Check Valves and simplify your GMP systems for enhanced manufacturing processes

NEUMO **BioFlow** Check Valves and their unique shut-off element **FLOWstop** provide optimal results when being used:

- / to prevent the re-flow of condensate
- / in ultra-pure steam, ultra-pure water and WFI systems
- / to protect sensitive sterile pumps and instruments from surges in pressure
- / in sampling systems for supplying WFI and ultra-pure water
- / in compressed air flushing and pressure flushing in sterile areas

Check Valves fulfil the following fundamental technical requirements:

- / pressure- and/or flow-dependent on/off function
- / self-acting, without external actuator
- / flow is only possible in one direction
- / flow is blocked in the opposite direction
- / quick reaction times
- / ability to prevent re-flow
- / protects pumps and instruments from water hammer

In accordance with cGMP (Current Good Manufacturing Practice) regulations, the following requirements come along when the valves are being used in the pharmaceutical industry and sterile areas:

- / avoidance of contamination and cross contamination
- / no fouling
- / optimal cleanability
- / low differential pressure

The NEUMO **FLOWstop** is available in two different materials:

- stainless steel 1.4435 / 316L
- PTFE

ADDITIONALLY TO OUR VALVES WE OFFER A WIDE RANGE OF SERVICES ON YOUR PREMISES

Our range of services includes:

- / service and maintenance of all Rieger products and other current valve and fittings manufacturers in your company
- / classic maintenance including I/O check and documentation
- / stock taking with parts lists of your plant to ensure a correct spare parts procurement
- / preventive maintenance with maintenance contract
- / optimization and engineering services

Additionally we offer trainings and developments for your team.



FURTHER BROCHURES



Further Rieger valve types upon request and in our catalogue. Contact your dedicated sales manager in our sales team in your area.

UPPER HOUSING

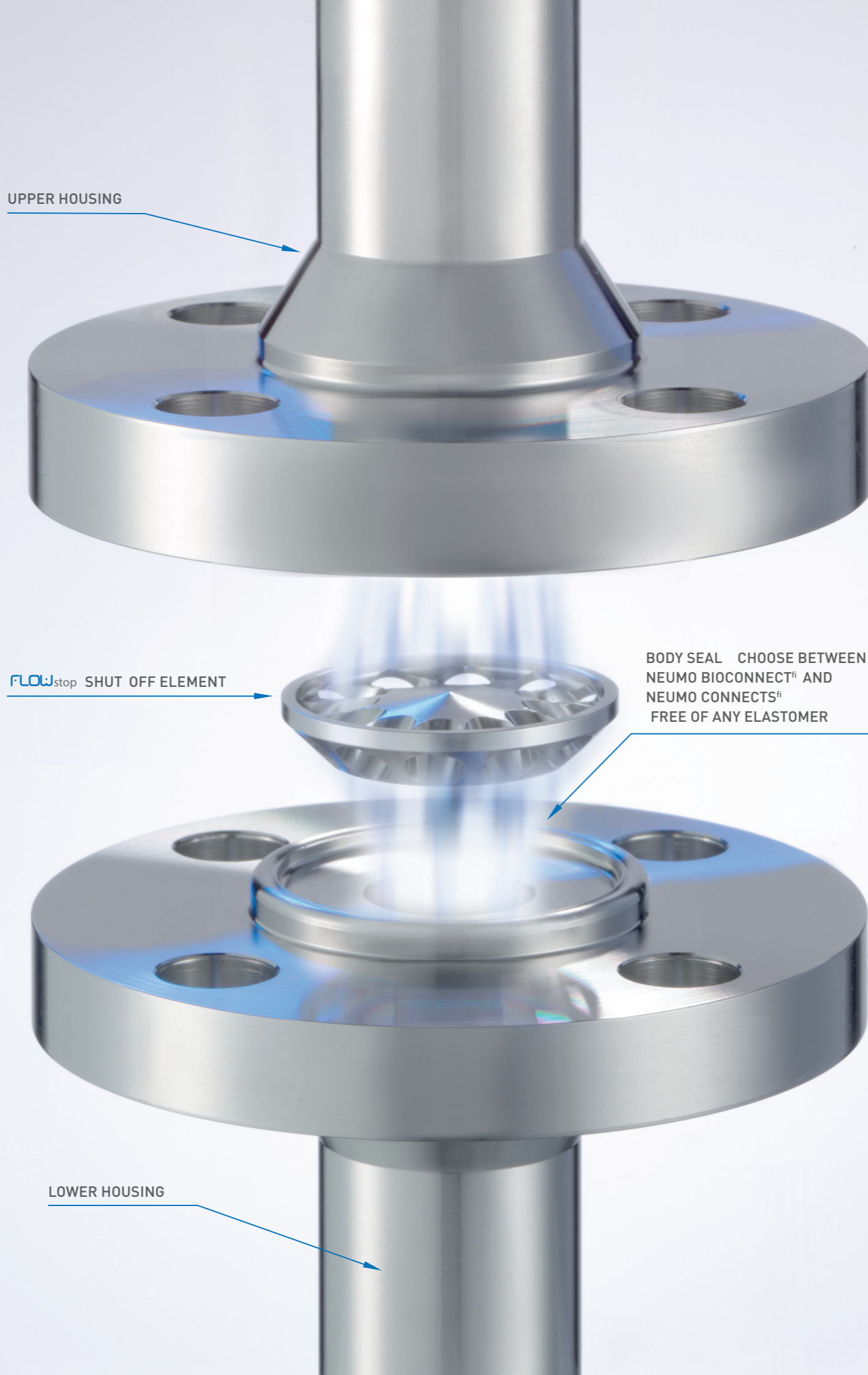

LOWER HOUSING

Benefits of NEUMO **BioFlow** Check Valves with **FLOWstop**:

Design benefits (BioFlow VC / HVC)

- / cGMP-compliant design and finish
- / excellent anti fouling characteristics
- / virtually no dead space
- / pharmaceutical grade surface finishes
- / uniform flow profile
- / optimal cleanability

Technical benefits

- / no springs or membranes
- / sophisticated state of the art design
- / ingeniously simple structure with only one moving part
- / the **FLOWstop** is guided axially due to the shape of the housing

Economic benefits

- / maintenance costs and downtime of pharmaceutical facilities are reduced
- / no need for orifice plates and expensive sensors to monitor flow rates
- / minimisation of process interruptions

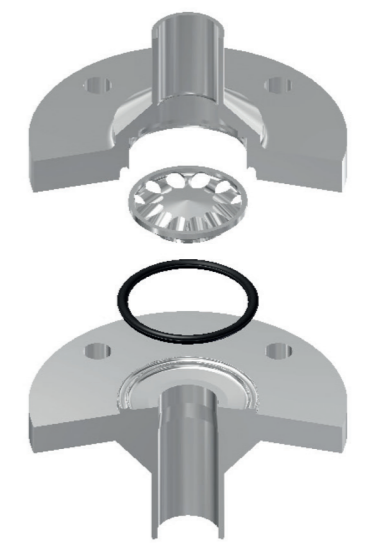

BioFlow VC
Check Valve
for vertical
installation

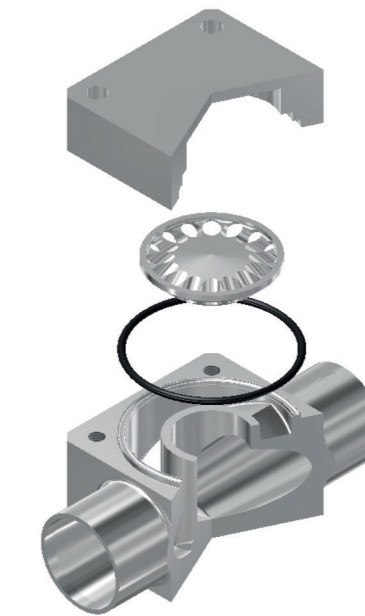

BioFlow HVC
Check Valve
for horizontal
Installation

BioFlow TCVC

Check Valve for vertical installation. Body is sealed by a clamp gasket in accordance with DIN32676 / ASME-BPE

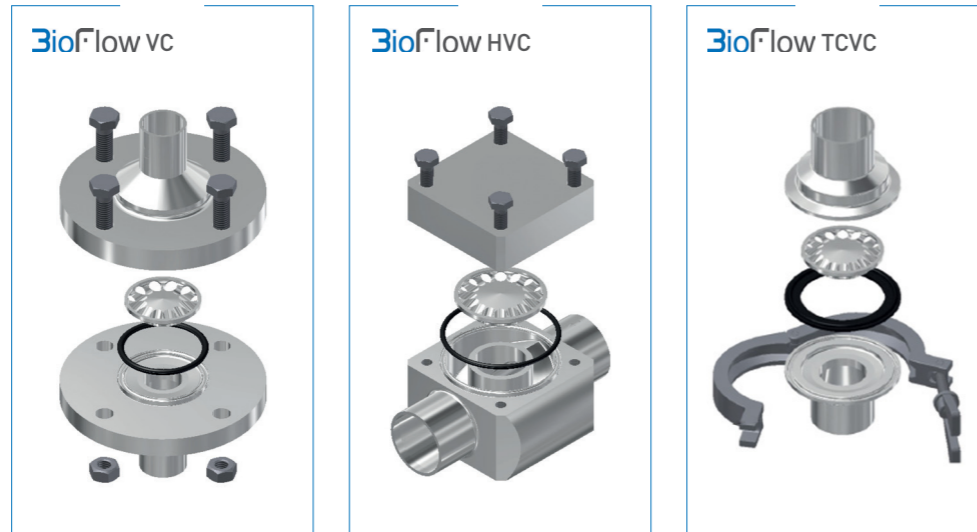

Technical Data

INSTALLATION	Vertical	Horizontal	Vertical
HOUSING MATERIAL*	/ 1.4435 / 316L acc. ASME-BPE		
SURFACE FINISH (PRODUCT CONTACTED AREA)*	/ Ra < 0,8 µm precision turned and electropolished		/ Ra < 0,8 µm precision turned
FLOWstop (SHUT-OFF ELEMENT)	/ Stainless steel 1.4435 / 316L with vulcanised O-ring EPDM / FDA + USP Class VI / PTFE / FDA + USP Class VI		
BODY SEAL*	/ NEUMO BioConnect® O-ring / NEUMO ConnectS® (free of any elastomer)		/ Clamp gasket / EPDM / FDA + USP Class VI
MAX. OPERATING PRESSURE	/ PN16 (at 20°C)		/ PN10 (at 20°C)
OPERATING TEMPERATURE	/ -10°C to +150°C		
DELTA-FERRITE CONTENT* (RAW MATERIAL)	/ <1%		
OPENING PRESSURE	/ 0.02 bar		
CONNECTIONS*	/ Orbital weld ends according to DIN11866 / Line A (DIN), line B (ISO), line C (ASME-BPE)		

* alternative materials (e.g. 2.4602, 2.4605, 1.4539, AL6XN, etc.), alternative materials for the body seal (e.g. FKM, FKM/FEP-encapsulated, PTFE, CleanLip®, etc.), differing connections, different surface finishes and delta-ferrite values are available on request.

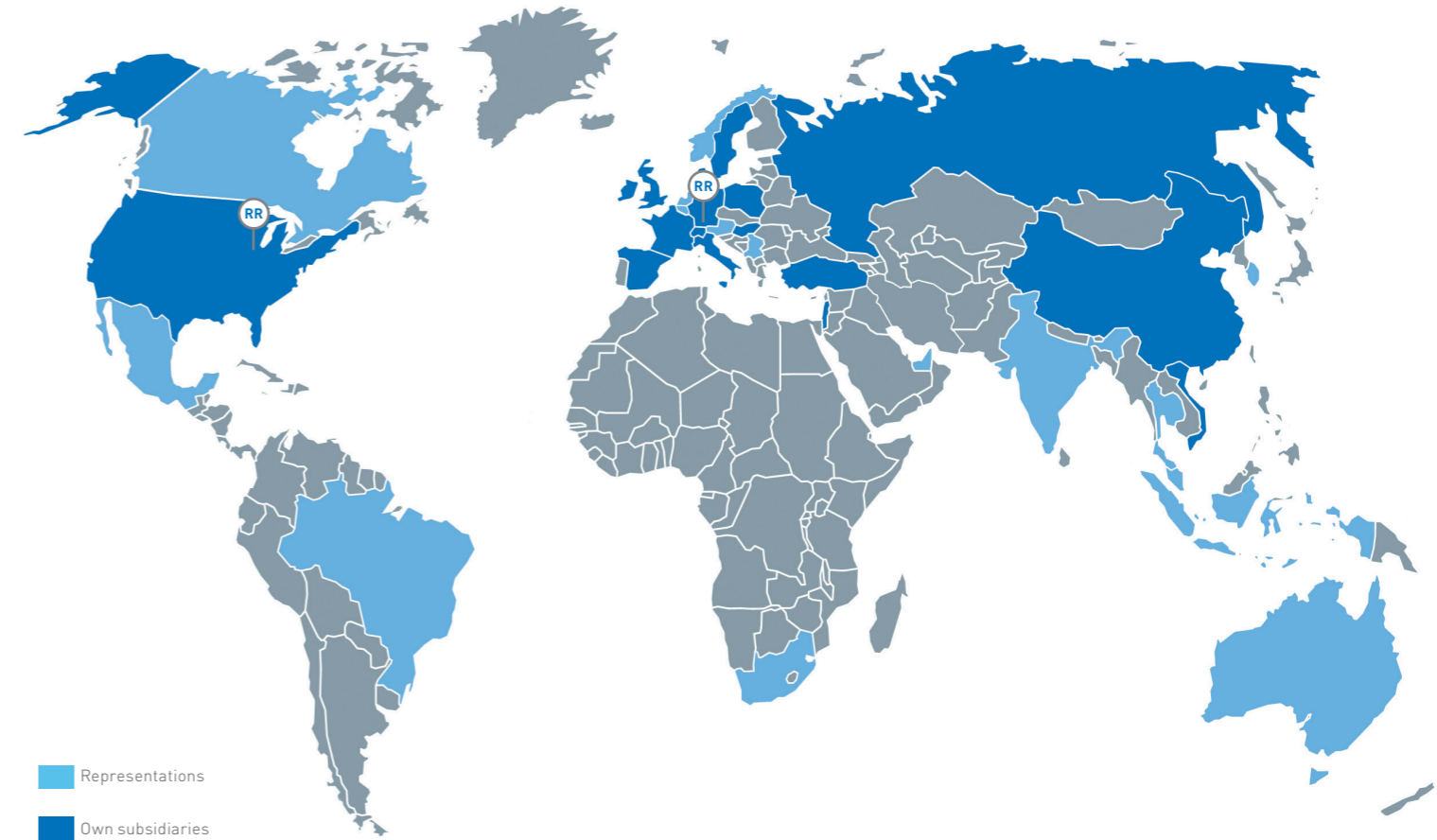

The **NEUMO Ehrenberg Group** is a family run holding, which is operating worldwide with more than 2.100 employees.

Since 1958 **Gebr. Rieger** has been a member of the NEUMO Ehrenberg Group. In our department valve technology Gebr. Rieger is successfully working in the **fields of valves, customized solutions**, such as **valve blocks** and **tubular structures** as well as **system engineering**, which includes **valve clusters, units, CIP-systems** and all kinds of **plug and play solutions**.

By its global approach Rieger gained international attention in the markets of **food, beverage** and **pharmaceutical industries**.

Besides the **Sampling Valves** the valve range also includes **Mix Proof Valves, Filling Valves** and **Pigging Systems**.

YOU DIDN'T FIND THE RIGHT VALVE?

Further Rieger valve types upon request and in our catalogue. Contact your dedicated sales manager in our sales team in your area.

DISTRIBUTED BY:

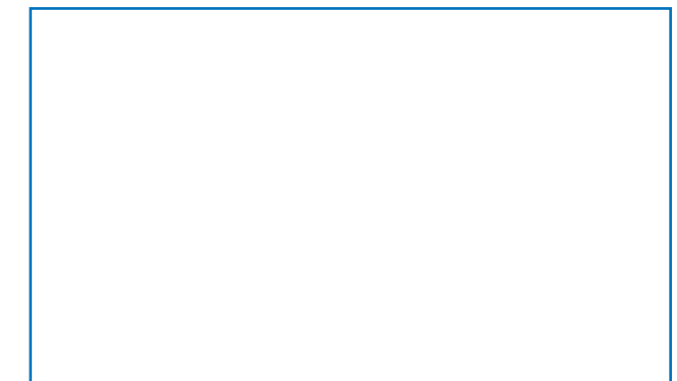

Gebr. Rieger GmbH + Co. KG
Kochertalstraße 32
DE-73431 Aalen
Phone: +49 7361 5702-0
Email: info@rr-rieger.de
www.rr-rieger.com